

tekmar® - Application

Difference Setpoint Control 155

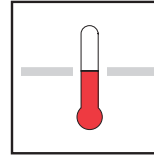

A 155-1
09/94

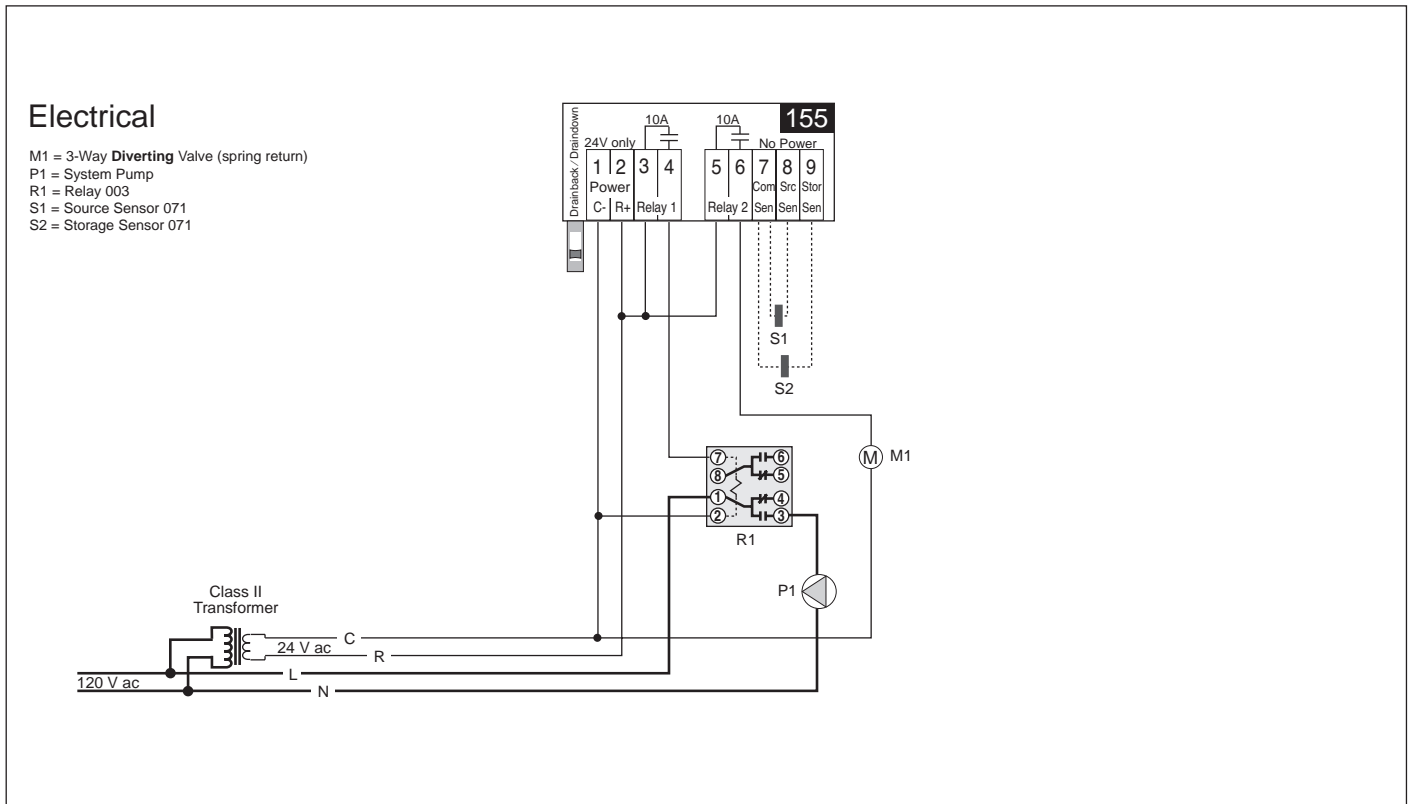
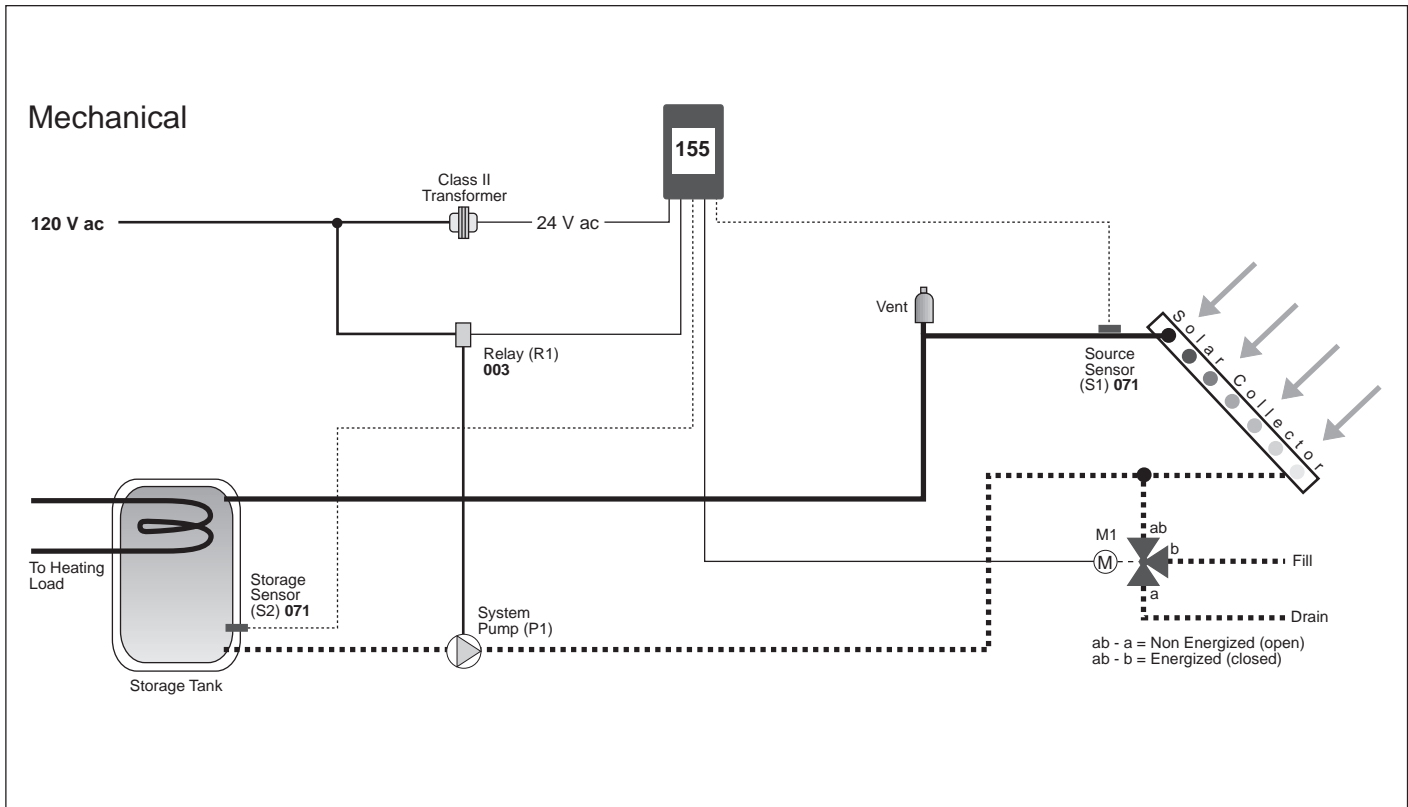

Note: This is only a concept drawing. The designer must determine whether this application will work in his system and must ensure compliance with code requirements. Necessary auxiliary equipment, isolation relays (for loads greater than the specified tekmar internal relay ratings), and other safety and limit devices must be added.

tekmar® - Application

Difference Setpoint Control 155

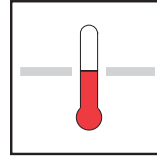

A 155-2
09/94

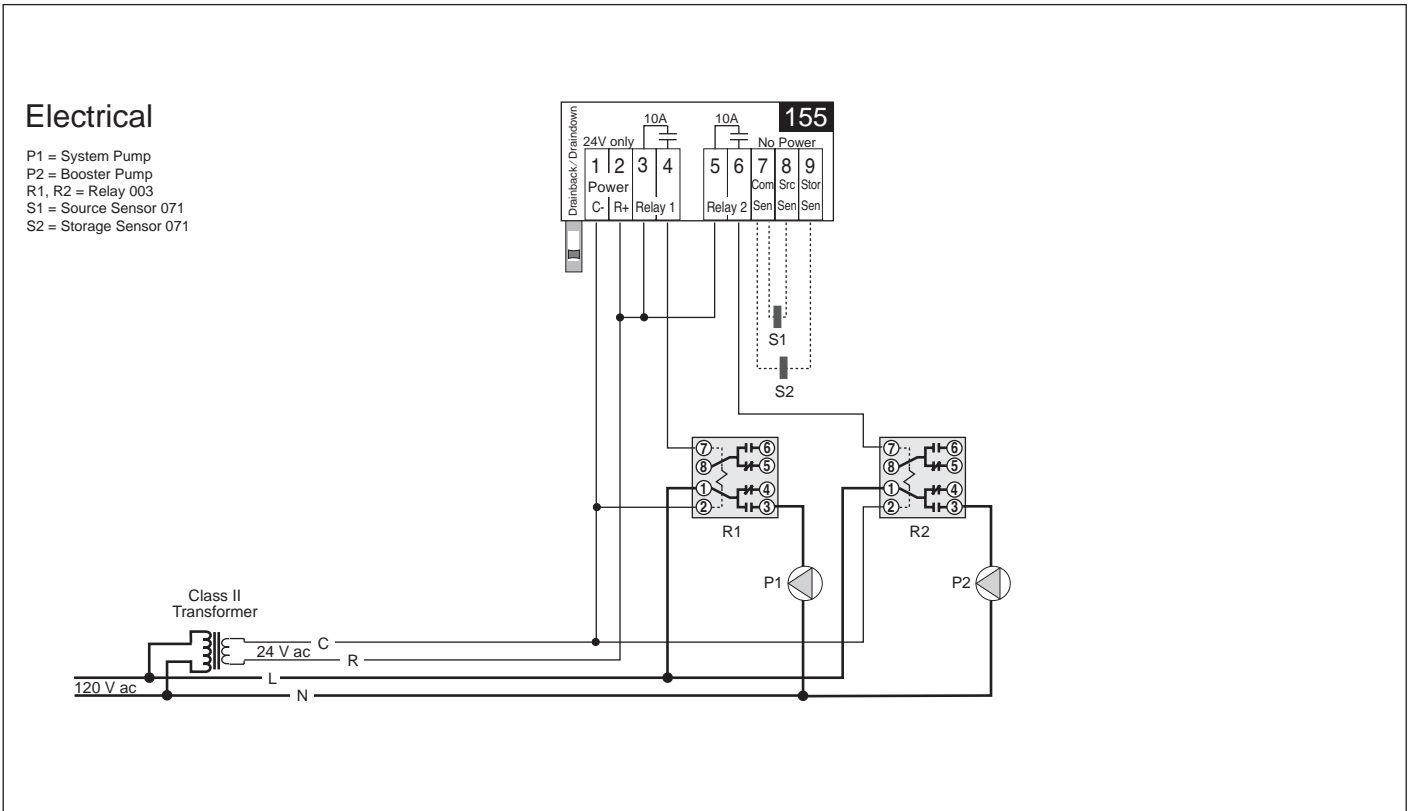
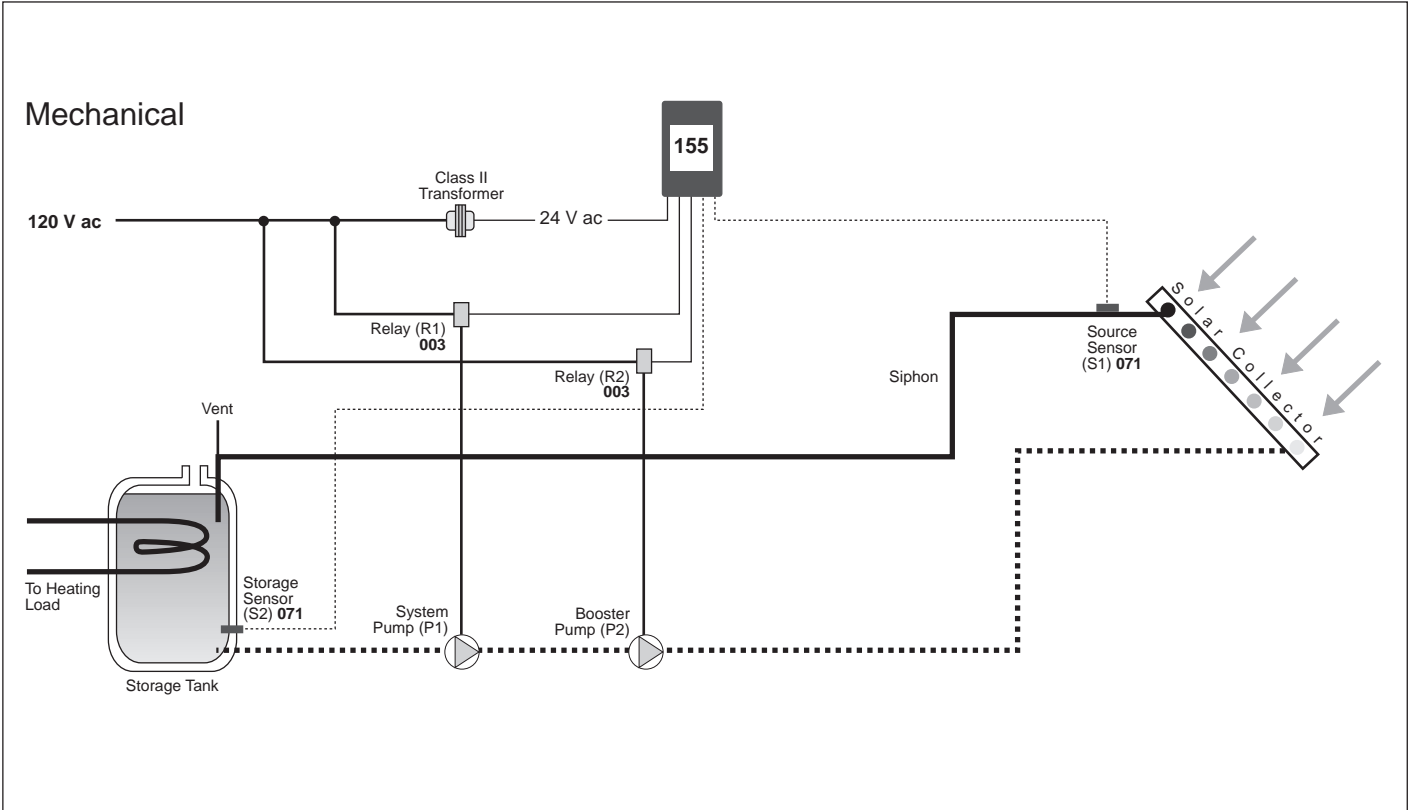

Note: This is only a concept drawing. The designer must determine whether this application will work in his system and must ensure compliance with code requirements. Necessary auxiliary equipment, isolation relays (for loads greater than the specified tekmar internal relay ratings), and other safety and limit devices must be added.

tekmar® - Application

Difference Setpoint Control 155

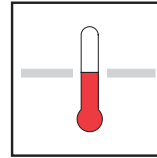

A 155-3
09/94

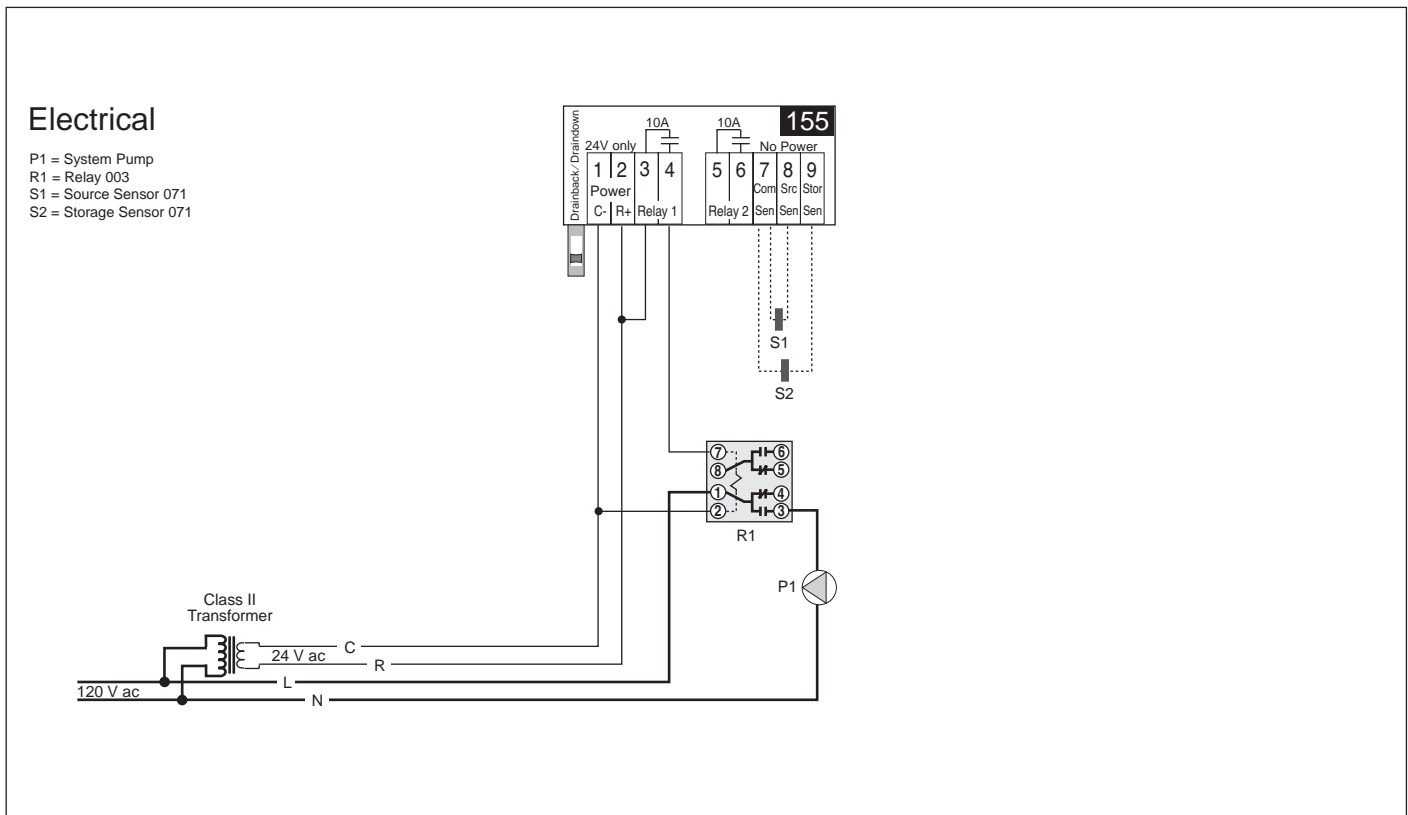
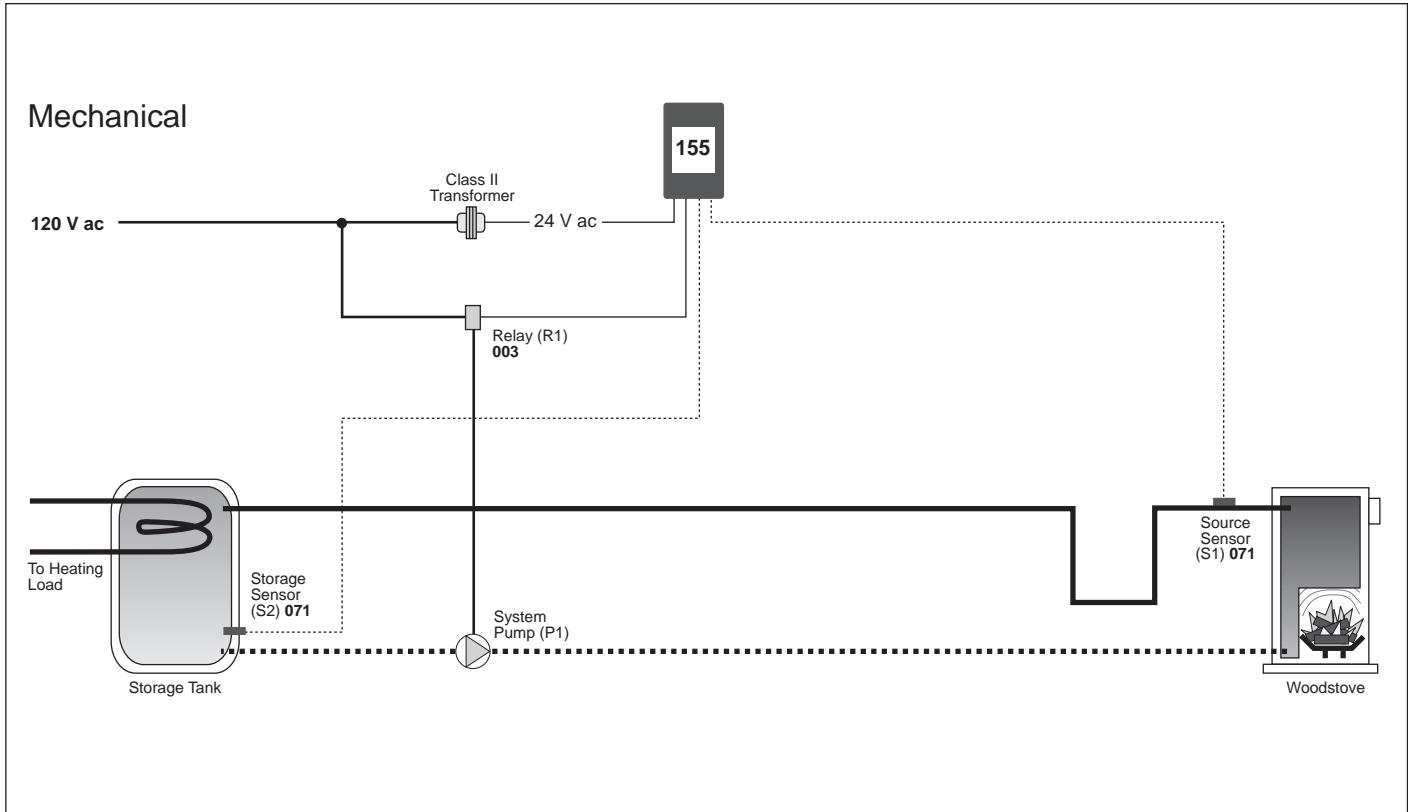

Note: This is only a concept drawing. The designer must determine whether this application will work in his system and must ensure compliance with code requirements. Necessary auxiliary equipment, isolation relays (for loads greater than the specified tekmar internal relay ratings), and other safety and limit devices must be added.

Difference Setpoint Control 155

- Literature — D 155, A 155, D 001, E 000, E 100
 Control — Microprocessor control; This is **not a safety (limit) control**.
 Packaged weight — 1.0 lb. (450 g), Enclosure C, PVC plastic
 Dimensions — 4-3/4" H x 2-7/8" W x 7/8" D (120 x 74 x 22 mm)
 Approvals — Meets DOC regulations for EMI/RFI.
 Ambient conditions — Indoor use only, -20 to 120°F (-30 to 50°C), < 90% RH non-condensing.
 Power supply — Class 2, 24 V ac ±10% 2 VA OR 30 V dc ±20% 0.03 A
 Relays — 120 V ac 10 A 1/3 hp, pilot duty 240 VA 2A
 Sensors — NTC thermistor, 10 kW @ 25°C ±0.2°C β=3892
 included: Two of Universal Sensor 071.
 Control accuracy — ±0.5°F (±0.25°C) with up to 1000 feet (300m) of 18 AWG wire to sensors.
- ΔT Setpoint* — 2 to 90°F (1 to 50°C)
ΔT Differential — 2 to 45°F (1 to 25°C)
Minimum Source — -22 to 185°F (-30 to 85°C)
Min. Source Diff'l — 2 to 45°F (1 to 25°C)
Maximum Storage — -4 to 248°F (-20 to 120°C)
Max. Storage Diff'l — 2 to 45°F (1 to 25°C)

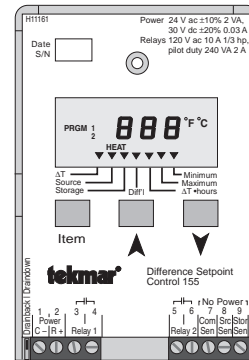

System Operation & Specifications

The tekmar Difference Setpoint Control 155 operates a System Pump whenever the temperature difference between the woodstove (source) and the storage tank is greater than a ΔT setpoint. The maximum and minimum temperatures measured at both the wood stove and the storage tank can be displayed by the control to monitor the system operation. The control can also display the total heat transferred from the stove to the storage tank.

The control shall meet the technical specifications listed above and shall provide the following functions.

- A System Pump shall be operated whenever the temperature difference between the wood stove and the storage tank is greater than a ΔT setpoint.
- The pump shall be turned off if the temperature within the storage tank exceeds a maximum setting.
- The woodstove source sensor shall be located on the exit of the stove and the storage tank sensor shall be located at the bottom of the tank to ensure an accurate ΔT reading is achieved.
- Adjustable differentials on each of the setpoints shall be provided to prevent short cycling of the pump. The setpoints shall be user programmable.
- The control shall display the measured temperatures at both the stove and the storage tank and also display the difference between these temperatures (ΔT). The control shall be able to display the items in both °C and °F.
- The control shall record and display the maximum and minimum temperatures measured at both the stove and the storage tank. The control shall also record and display the $\Delta T \cdot \text{hours}$ of operation such that the energy transfer from the stove to the storage tank can be calculated.
- The control shall continuously monitor the sensors and provide an LCD error message if a sensor or its wiring develops a short or open circuit.
- The installer must ensure that the control and its wiring are isolated and/or shielded from strong sources of electromagnetic noise.
- **Order the following components for this application:** one Difference Setpoint Control 155 and one Relay 003.

| | |
|--------------------------|---|
| In North America: | tekmar Control Systems Ltd., Canada tekmar Control Systems, Inc., U.S.A. Head Office: 5100 Silver Star Road Vernon, B.C. Canada V1B 3K4 Tel. (250) 545-7749 Fax. (250) 545-0650 |
|--------------------------|---|