

Features of the Universal Reset Control 364

Please refer to Essay E 005: Control Functions and Benefits for a detailed description of these features.

- | | |
|---|--|
| 2 Characterized Heating Curve | 26 DHW Mixing Purge |
| 6 Indoor Temperature Feedback | 29 Setpoint Boiler Reset Override |
| 7 Warm Weather Shut Down | 31 Mixing Outdoor Reset |
| 8 Boiler Outdoor Reset | 32 Floating Action Output |
| 10 Boiler Differential (Automatic) | 35 Variable Speed Output |
| 11 Boiler Minimum Supply | 37 Boiler Protection |
| 13 Boiler Post Purge | 38 System Protection |
| 19 Fire Delay | 39 Boiler Load Reset |
| 20 Boiler Mass | 53 Slab Protection |
| 21 Boiler Enable | 55 Slab Outdoor Reset |
| 22 DHW Boiler Reset Override | 56 Snow Melting Setpoint |
| 23 DHW Priority | 57 Snow Idling Setpoint |
| 24 DHW Priority Override | 59 Cold Weather Cut Off |
| 25 DHW Post Purge | 60 Pump / Integrated Exercising |

Application

The Universal Reset Control 364 is designed to maximize the comfort and efficiency provided by a hydronic heating system. The control automatically adjusts the boiler and mixed loop water temperatures that are delivered to the heating system by using outdoor reset. For a mixing device, the 364 can use either a variable speed injection pump or a floating action mixing valve. The mixed water temperature can be used to supply either a space heating system or a single zone snow melting system. The 364 is capable of controlling an indirect Domestic Hot Water (DHW) storage tank and / or a setpoint load. The temperature of individual zones can be controlled by connecting either a conventional thermostat system or a tekmar zone control to the 364.

- A1 = Aquastat
- D1 = Remote Display Module 040
- P1 = Primary Pump
- P2 = Boiler System Pump
- P3 = Mix System Pump
- P4 = Variable Speed Injection Pump
- P5 = DHW Pump
- S1 = Outdoor Sensor 070
- S2 = Boiler Supply Sensor 071
- S3 = Mix Supply Sensor 071
- T1, ..., T6 = Thermostats
- V1 = Balancing Valve or Globe Valve
- Z1, ..., Z3 = Mix Zone Valve
- Z4, ..., Z6 = Boiler Zone Valve

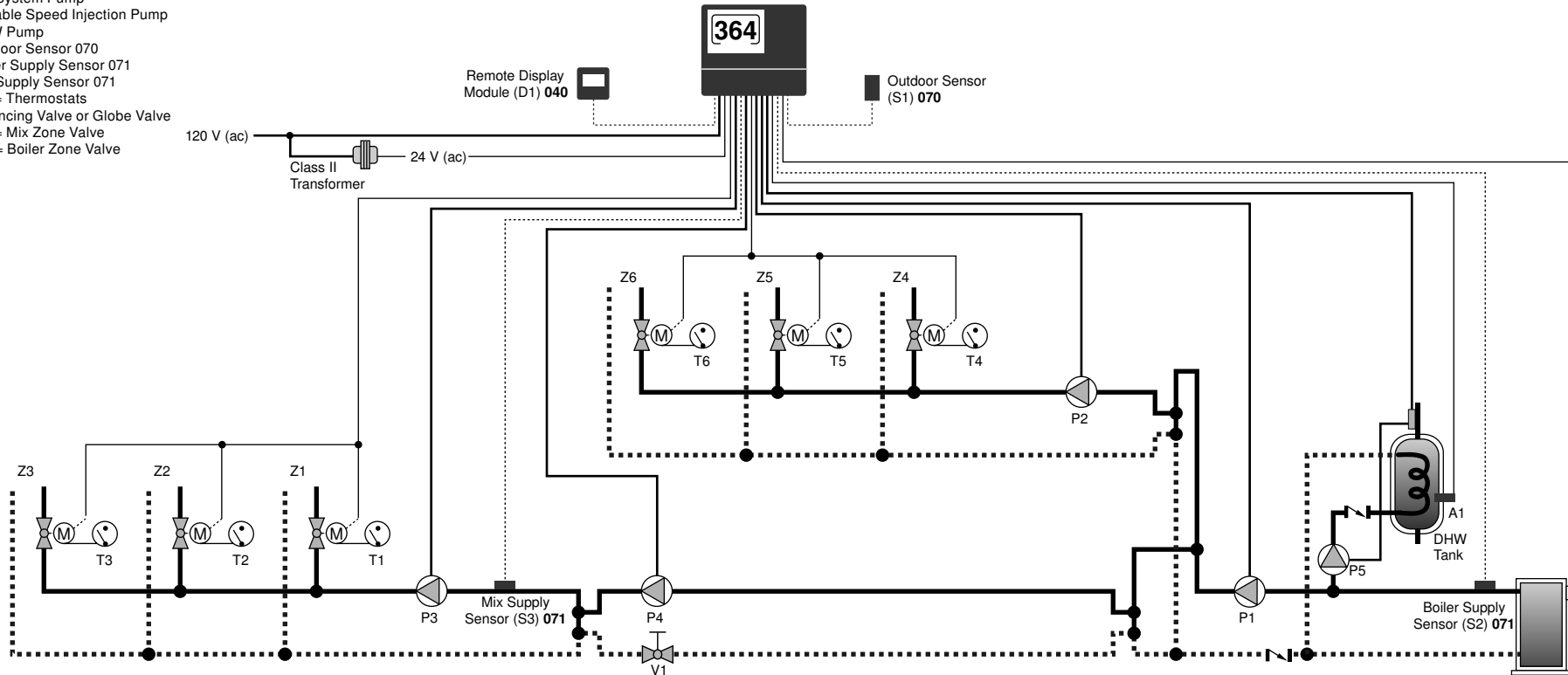

Concept Drawing

This is only a concept drawing, not an engineered drawing. It is not intended to describe a complete system, nor any particular system. It is up to the system designer to determine the necessary components for and configuration of the particular system being designed, including additional equipment, isolation relays (for loads greater than the control's specified output ratings), and any safety devices which in the judgement of the designer are appropriate, in order to properly size, configure and design that system and to ensure compliance with building and safety code requirements.

System Operation

The Universal Reset Control 364 provides full outdoor reset to three (or more) mixed zones and partial outdoor reset to three (or more) boiler zones. The output of the variable speed injection pump is modulated to provide a mixed supply water temperature to the mixed zones, and protect the boiler from flue gas condensation. The 364 also controls the supply of heat to an indirect Domestic Hot Water (DHW) tank. The boiler operates at the required temperature in order to satisfy all loads.

- A1 = Aquastat
- D1 = Remote Display Module 040
- P1 = Primary Pump
- P2 = Boiler System Pump
- P3 = Mix System Pump
- P4 = Variable Speed Injection Pump
- P5 = DHW Pump
- S1 = Outdoor Sensor 070
- S2 = Boiler Supply Sensor 071
- S3 = Mix Supply Sensor 071
- T1, ..., T6 = Thermostats
- V1 = Balancing Valve or Globe Valve
- Z1, ..., Z3 = Mix Zone Valve
- Z4, ..., Z6 = Boiler Zone Valve

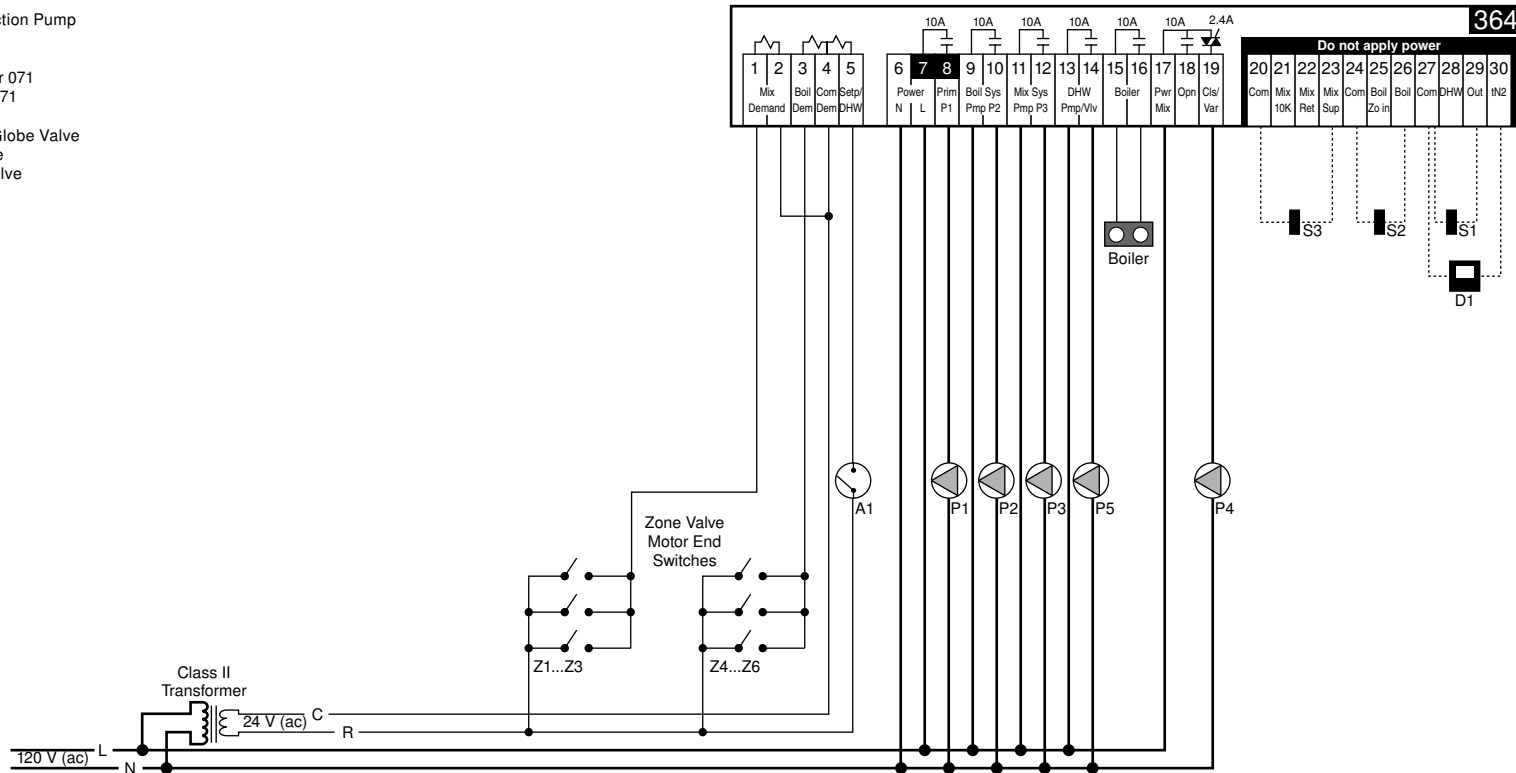

3 of 12

© 2001 tekmar[®] A 364 - 07/01

Concept Drawing

This is only a concept drawing, not an engineered drawing. It is not intended to describe a complete system, nor any particular system. It is up to the system designer to determine the necessary components for and configuration of the particular system being designed, including additional equipment, isolation relays (for loads greater than the control's specified output ratings), and any safety devices which in the judgement of the designer are appropriate, in order to properly size, configure and design that system and to ensure compliance with building and safety code requirements.

Essential Control Settings

DIP Switch = Mixing Reset
 MIXING = VAR
 DHW THRU = PUMP

MIX 10K = NONE
 Boil SENS = SUP
 DHW SENS = NONE

tekmar Control Systems Ltd., Canada; tekmar Control Systems, Inc., U.S.A.; www.tekmarcontrols.com
 Head Office: 4611-23rd Street, Vernon, B.C. Canada, V1T 4K7; (250) 545-7749 Fax (250) 545-0650

- C1 = Actuating Motor 011
- D1 = Remote Display Module 040
- P1 = Primary Pump
- P2 = Boiler System Pump
- R1, ... R3 = Relay 003
- S1 = DHW Sensor 071
- S2 = Outdoor Sensor 070
- S3 = Boiler Supply Sensor 071
- S4 = Mix Supply Sensor 071
- T1, ... T6 = Thermostats
- V1 = DHW Valve
- V2 = 4-Way Mixing Valve
- V3 = Balancing Valve or Pressure Bypass Valve
- Z1, ... Z3 = Mix Zone Pump
- Z4, ... Z6 = Boiler Zone Valve

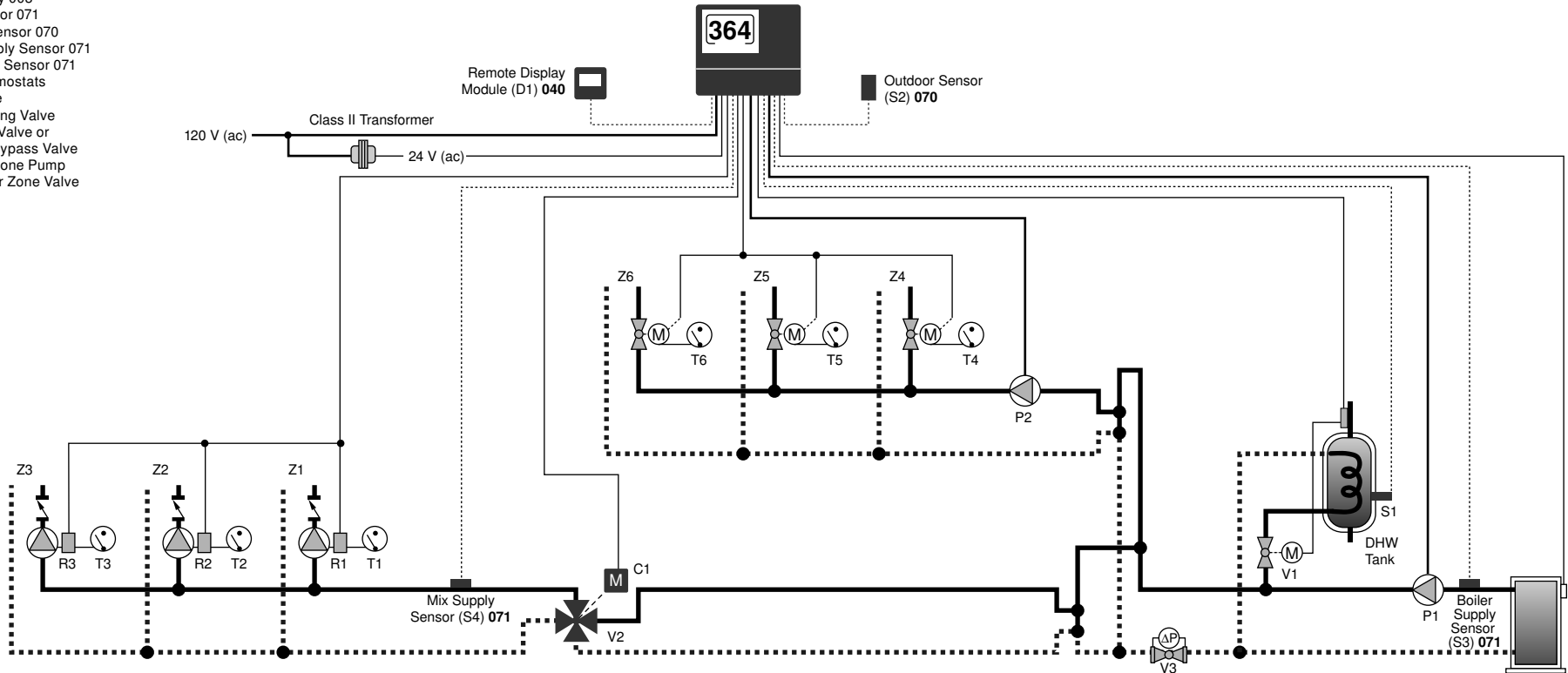

Concept Drawing

This is only a concept drawing, not an engineered drawing. It is not intended to describe a complete system, nor any particular system. It is up to the system designer to determine the necessary components for and configuration of the particular system being designed, including additional equipment, isolation relays (for loads greater than the control's specified output ratings), and any safety devices which in the judgement of the designer are appropriate, in order to properly size, configure and design that system and to ensure compliance with building and safety code requirements.

System Operation

The Universal Reset Control 364 provides full outdoor reset to three (or more) mixed zones and partial outdoor reset to three (or more) boiler zones. The position of the mixing valve is modulated to provide a mixed supply water temperature to the mixed zones, and protect the boiler from flue gas condensation. The 364 also controls the supply of heat to an indirect Domestic Hot Water (DHW) tank. The boiler operates at the required temperature in order to satisfy all loads.

- C1 = Actuating Motor 011
- D1 = Remote Display Module 040
- P1 = Primary Pump
- P2 = Boiler System Pump
- R1, ..., R3 = Relay 003
- S1 = DHW Sensor 071
- S2 = Outdoor Sensor 070
- S3 = Boiler Supply Sensor 071
- S4 = Mix Supply Sensor 071
- T1, ..., T6 = Thermostats
- V1 = DHW Valve
- V2 = 4-Way Mixing Valve
- V3 = Balancing Valve or Pressure Bypass Valve
- Z1, ..., Z3 = Mix Zone Pump
- Z4, ..., Z6 = Boiler Zone Valve

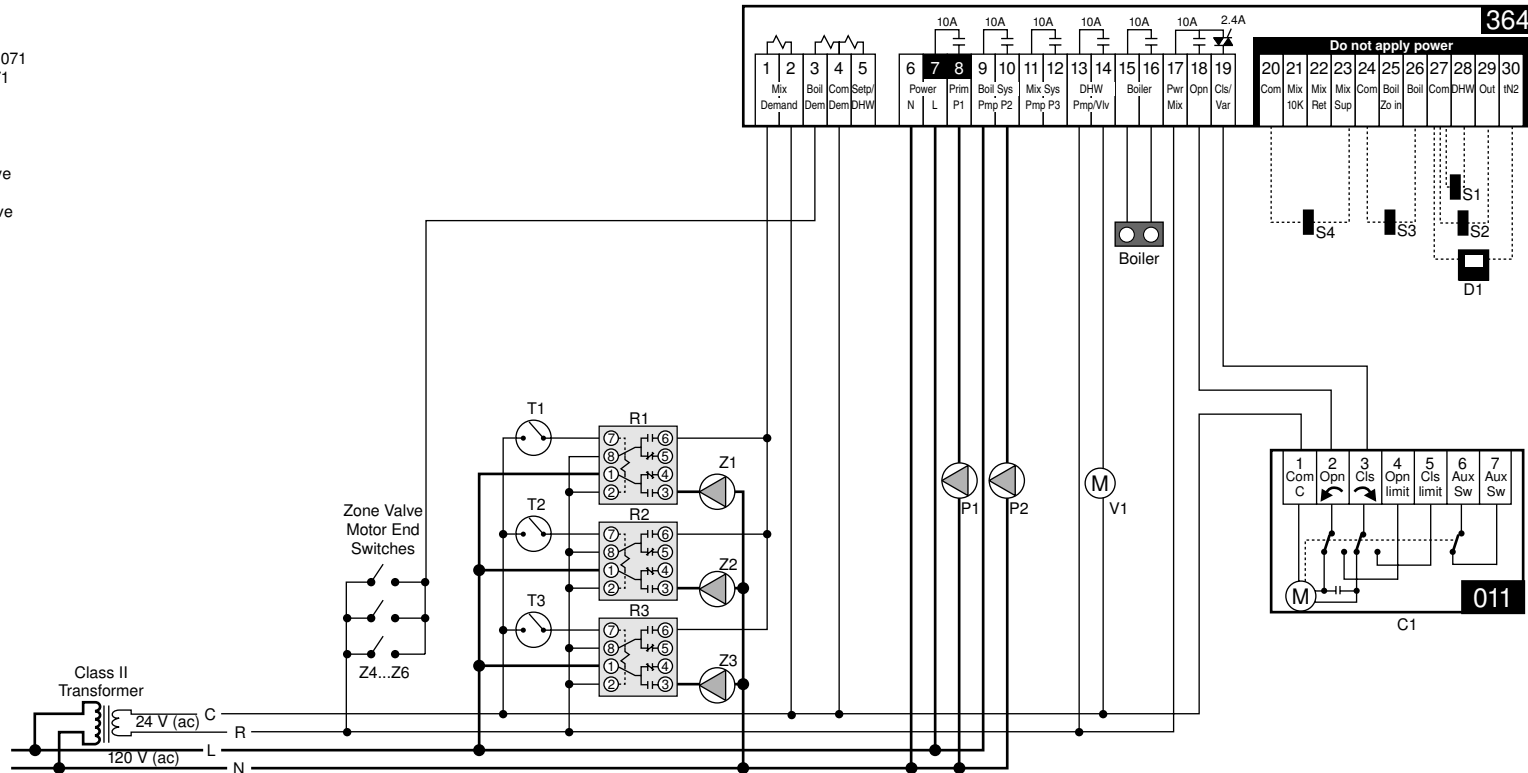

5 of 12

© 2001 tekmar® A 364 - 07/01

Concept Drawing

This is only a concept drawing, not an engineered drawing. It is not intended to describe a complete system, nor any particular system. It is up to the system designer to determine the necessary components for and configuration of the particular system being designed, including additional equipment, isolation relays (for loads greater than the control's specified output ratings), and any safety devices which in the judgement of the designer are appropriate, in order to properly size, configure and design that system and to ensure compliance with building and safety code requirements.

Essential Control Settings

DIP Switch = Mixing Reset
 Boil SENS = SUP
 DHW SENS = DHW

MIX 10K = NONE
 DHW THRU = VALV
 MIXING = FLOT

tekmar Control Systems Ltd., Canada; tekmar Control Systems, Inc., U.S.A.; www.tekmarcontrols.com
 Head Office: 4611-23rd Street, Vernon, B.C. Canada, V1T 4K7; (250) 545-7749 Fax (250) 545-0650

- A1 = Aquastat
- D1 = Remote Start/Stop Module 039
- P1 = Primary Pump
- P2 = Boiler System Pump
- P3 = Mix System Pump
- P4 = Variable Speed Injection Pump
- P5 = DHW Pump
- S1 = Outdoor Sensor 070
- S2 = Boiler Supply Sensor 071
- S3 = Slab Sensor 072/073
- S4 = Mix Return Sensor 071
- S5 = Mix Supply Sensor 071
- T1, ... T3 = Thermostats
- V1 = Balancing Valve or Globe Valve
- Z1, ... Z3 = Boiler Zone Valve

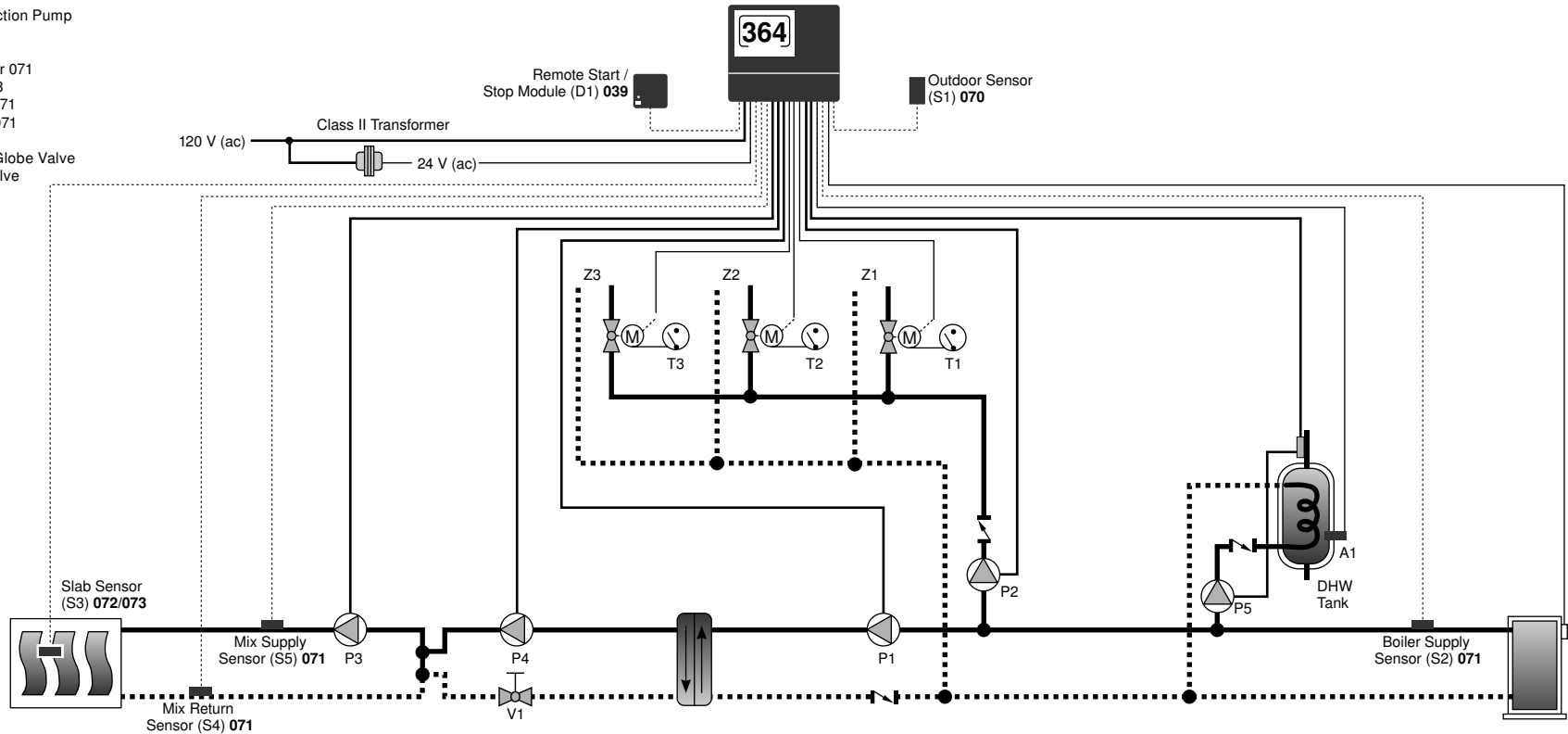

Concept Drawing

This is only a concept drawing, not an engineered drawing. It is not intended to describe a complete system, nor any particular system. It is up to the system designer to determine the necessary components for and configuration of the particular system being designed, including additional equipment, isolation relays (for loads greater than the control's specified output ratings), and any safety devices which in the judgement of the designer are appropriate, in order to properly size, configure and design that system and to ensure compliance with building and safety code requirements.

System Operation

The Universal Reset Control 364 provides partial outdoor reset to three (or more) boiler zones and snow melting for a single zone system. The output of the variable speed injection pump is modulated to mix down the boiler supply fluid temperature to protect the slab from thermal stress and to protect the boiler from flue gas condensation. The 364 also controls the supply of heat to an indirect Domestic Hot Water (DHW) tank. The boiler operates at the required temperature in order to satisfy all loads.

- A1 = Aquastat
- D1 = Remote Start/Stop Module 039
- P1 = Primary Pump
- P2 = Boiler System Pump
- P3 = Mix System Pump
- P4 = Variable Speed Injection Pump
- P5 = DHW Pump
- S1 = Outdoor Sensor 070
- S2 = Boiler Supply Sensor 071
- S3 = Slab Sensor 072/073
- S4 = Mix Return Sensor 071
- S5 = Mix Supply Sensor 071
- T1, ... T3 = Thermostats
- V1 = Balancing Valve or Globe Valve
- Z1, ... Z3 = Boiler Zone Valve

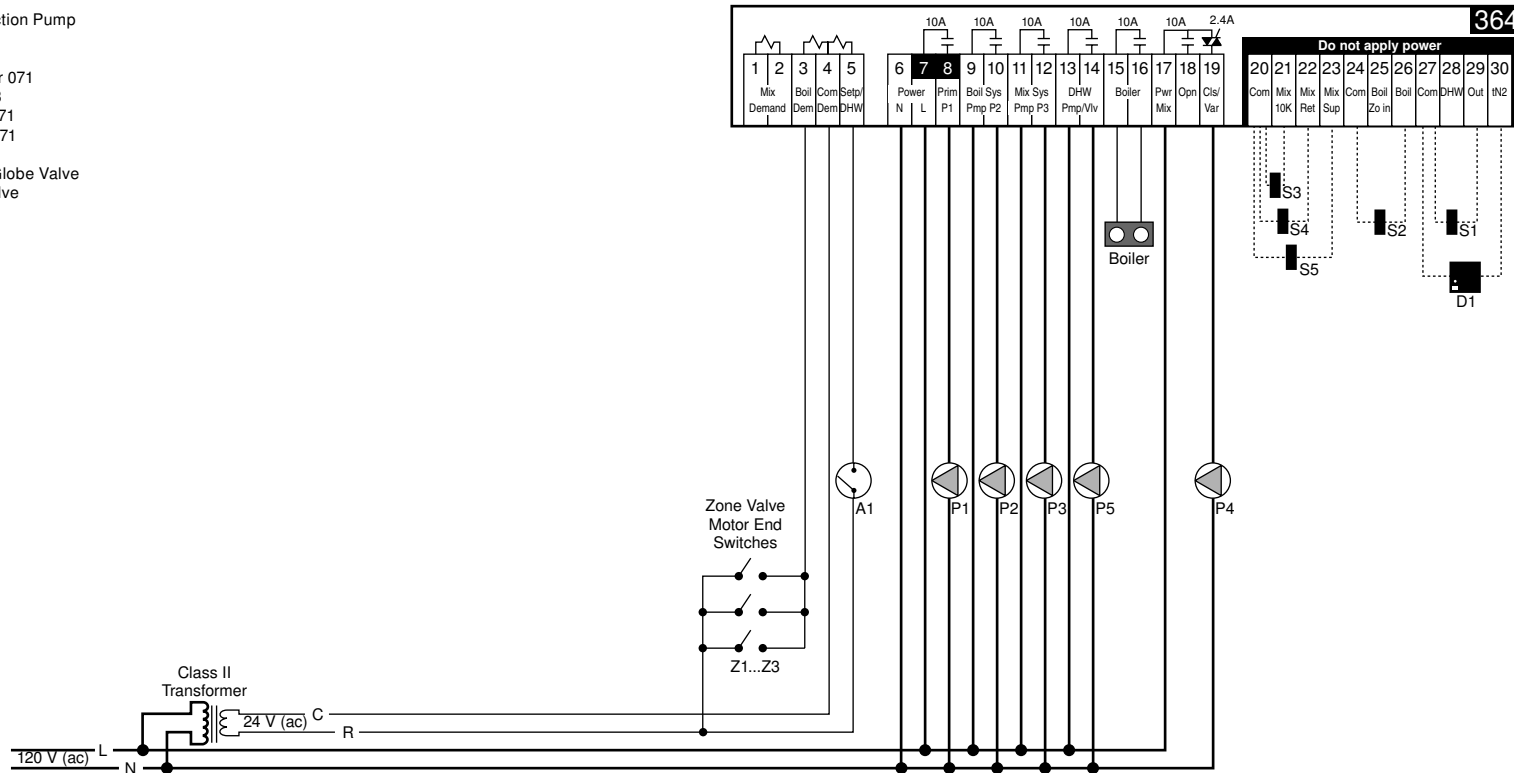

7 of 12

© 2001 tekmar® A 364 - 07/01

Concept Drawing

This is only a concept drawing, not an engineered drawing. It is not intended to describe a complete system, nor any particular system. It is up to the system designer to determine the necessary components for and configuration of the particular system being designed, including additional equipment, isolation relays (for loads greater than the control's specified output ratings), and any safety devices which in the judgement of the designer are appropriate, in order to properly size, configure and design that system and to ensure compliance with building and safety code requirements.

Essential Control Settings

DIP Switch = Snow Melting MIXING = VAR
 MIX 10K = SLAB DHW SENS = NONE
 Boil SENS = SUP
 DHW THRU = PUMP

tekmar Control Systems Ltd., Canada; tekmar Control Systems, Inc., U.S.A.; www.tekmarcontrols.com
 Head Office: 4611-23rd Street, Vernon, B.C. Canada, V1T 4K7; (250) 545-7749 Fax (250) 545-0650

- A1 = Aquastat
- C1 = Actuating Motor 011
- P1 = Primary Pump
- P2 = Boiler System Pump
- P3 = DHW Pump
- R1, ..., R3 = Relay 003
- S1 = Boiler Supply Sensor 071
- S2, S3 = Outdoor Sensor 070
- S4 = Boiler Return Sensor 071
- S5 = Mix Supply Sensor 071
- T1, ..., T6 = Thermostats
- V1 = 4-Way Mixing Valve
- Z1, ..., Z3 = Mix Zone Pump
- Z4, ..., Z6 = Boiler Zone Valve

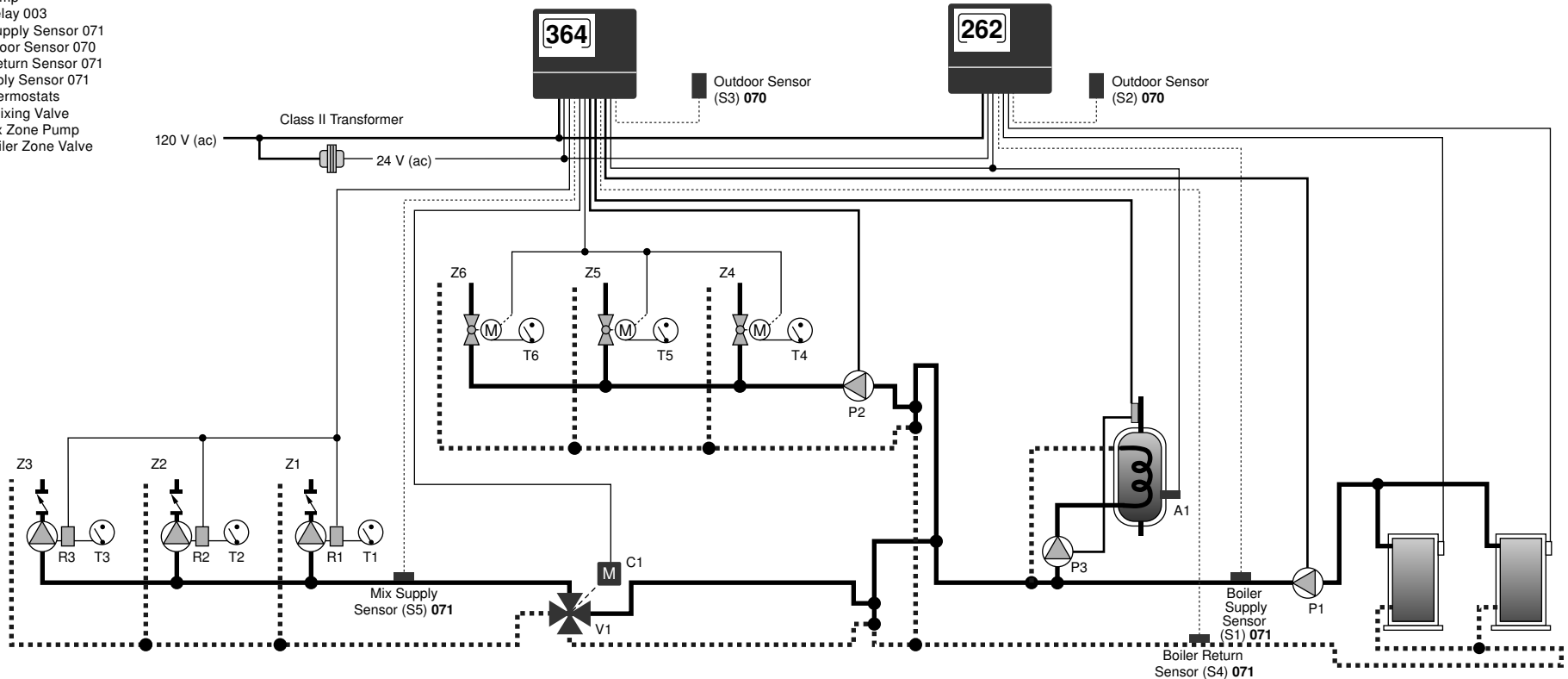

Concept Drawing

This is only a concept drawing, not an engineered drawing. It is not intended to describe a complete system, nor any particular system. It is up to the system designer to determine the necessary components for and configuration of the particular system being designed, including additional equipment, isolation relays (for loads greater than the control's specified output ratings), and any safety devices which in the judgement of the designer are appropriate, in order to properly size, configure and design that system and to ensure compliance with building and safety code requirements.

System Operation

The Universal Reset Control 364 and the Boiler Control 262 are combined to provide full outdoor reset to three (or more) mixed zones and partial outdoor reset to three (or more) boiler zones. The position of the mixing valve is modulated to provide a mixed supply water temperature to the mixed zones and protect the boiler from flue gas condensation. The 364 also controls the supply of heat to an indirect Domestic Hot Water (DHW) tank. The boilers operate at the required temperature in order to satisfy all loads.

- A1 = Aquastat
- C1 = Actuating Motor 011
- P1 = Primary Pump
- P2 = Boiler System Pump
- P3 = DHW Pump
- R1, ... R3 = Relay 003
- S1 = Boiler Supply Sensor 071
- S2, S3 = Outdoor Sensor 070
- S4 = Boiler Return Sensor 071
- S5 = Mix Supply Sensor 071
- T1, ... T6 = Thermostats
- V1 = 4-Way Mixing Valve
- Z1, ... Z3 = Mix Zone Pump
- Z4, ... Z6 = Boiler Zone Valve

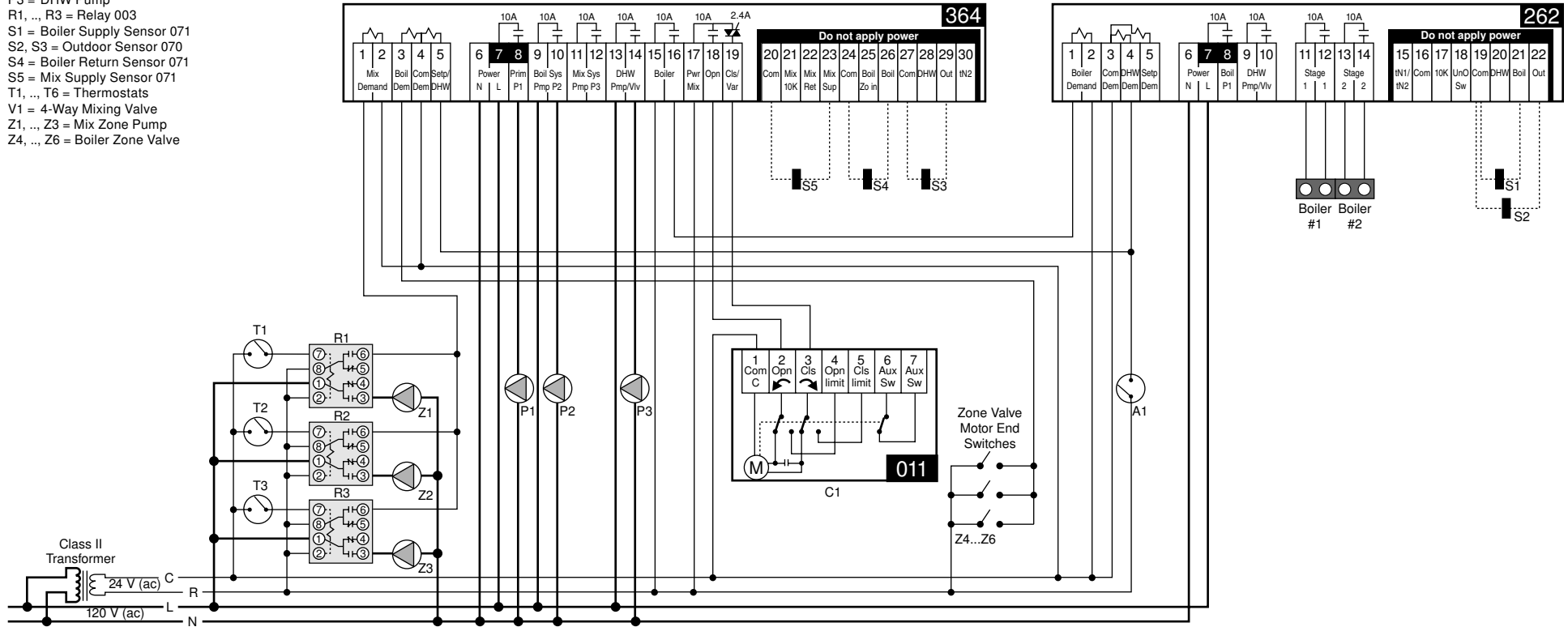

9 of 12

© 2001 tekmar® A 364 - 07/01

Concept Drawing

This is only a concept drawing, not an engineered drawing. It is not intended to describe a complete system, nor any particular system. It is up to the system designer to determine the necessary components for and configuration of the particular system being designed, including additional equipment, isolation relays (for loads greater than the control's specified output ratings), and any safety devices which in the judgement of the designer are appropriate, in order to properly size, configure and design that system and to ensure compliance with building and safety code requirements.

Essential Control Settings

- | | |
|---------------------------------------|----------------------|
| 364: DIP Switch = Mixing Reset | 262: MODE = 1 |
| MIXING = FLOT | STAGE 1 = AUTO |
| Boil SENS = RET | STAGE 2 = AUTO |
| DHW THRU = VALV | |
| DHW SENS = NONE | |

tekmar Control Systems Ltd., Canada; tekmar Control Systems, Inc., U.S.A.; www.tekmarcontrols.com
 Head Office: 4611-23rd Street, Vernon, B.C. Canada, V1T 4K7; (250) 545-7749 Fax (250) 545-0650

- A1 = Aquastat
- D1 = Remote Display Module 040
- P1 = Primary Pump
- P2 = Variable Speed Injection Pump
- P3 = Mix System Pump
- P4 = DHW Pump
- S1 = Outdoor Sensor 070
- S2 = Boiler Supply Sensor 071
- S3 = Mix Supply Sensor 071
- V1 = Balancing Valve or Globe Valve
- Z1, ... Z4 = Mix Zone Valves
- Z5, ... Z8 = Boiler Zone Pumps

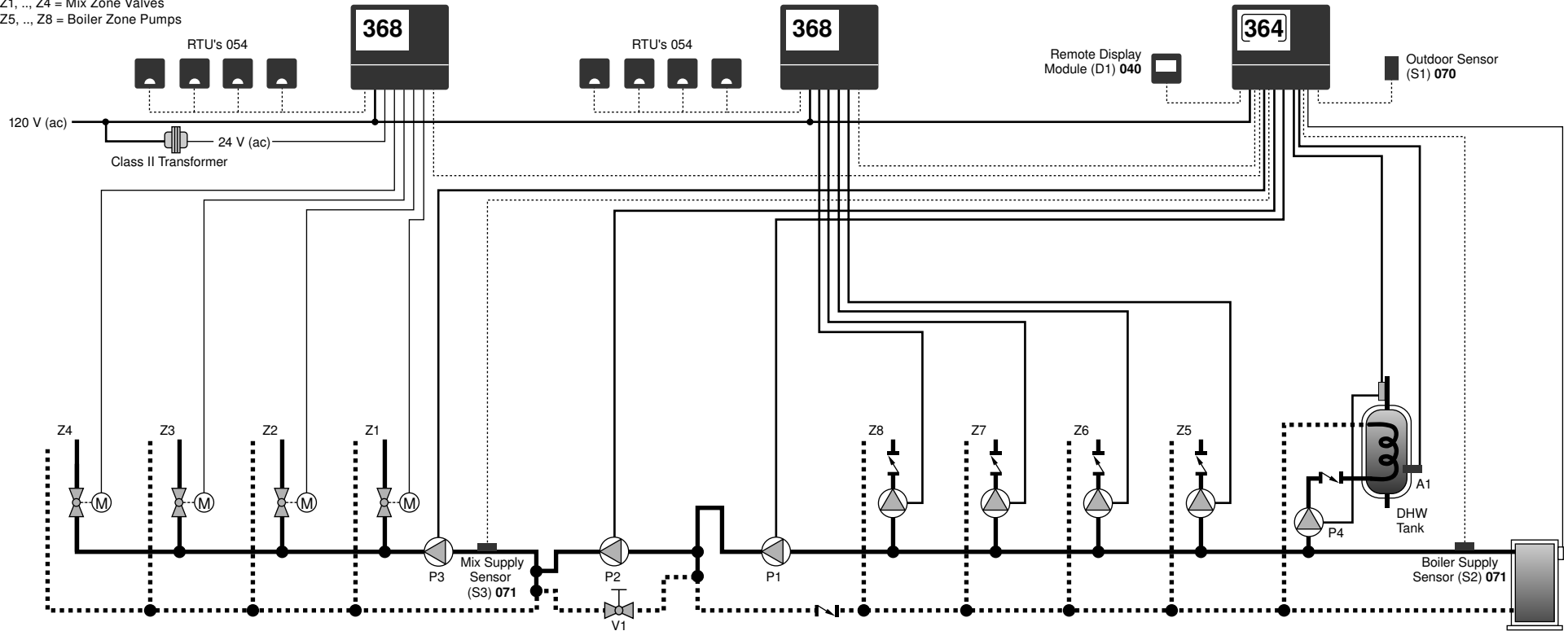

Concept Drawing

This is only a concept drawing, not an engineered drawing. It is not intended to describe a complete system, nor any particular system. It is up to the system designer to determine the necessary components for and configuration of the particular system being designed, including additional equipment, isolation relays (for loads greater than the control's specified output ratings), and any safety devices which in the judgement of the designer are appropriate, in order to properly size, configure and design that system and to ensure compliance with building and safety code requirements.

System Operation

The Universal Reset Control 364 and two Zone Control 368's are combined to provide full outdoor reset to four mixed zones and partial outdoor reset to four boiler zones. The output of the variable speed injection pump is modulated to provide a mixed supply water temperature to the mixed zones, and protect the boiler from flue gas condensation. The 364 also controls the supply of heat to an indirect Domestic Hot Water (DHW) tank. The boiler operates at the required temperature in order to satisfy all loads.

A1 = Aquastat
 D1 = Remote Display Module 040
 P1 = Primary Pump
 P2 = Variable Speed Injection Pump
 P3 = Mix System Pump
 P4 = DHW Pump
 S1 = Outdoor Sensor 070
 S2 = Boiler Supply Sensor 071

S3 = Mix Supply Sensor 071
 V1 = Balancing Valve or Globe Valve
 Z1, ..., Z4 = Mix Zone Valves
 Z5, ..., Z8 = Boiler Zone Pumps

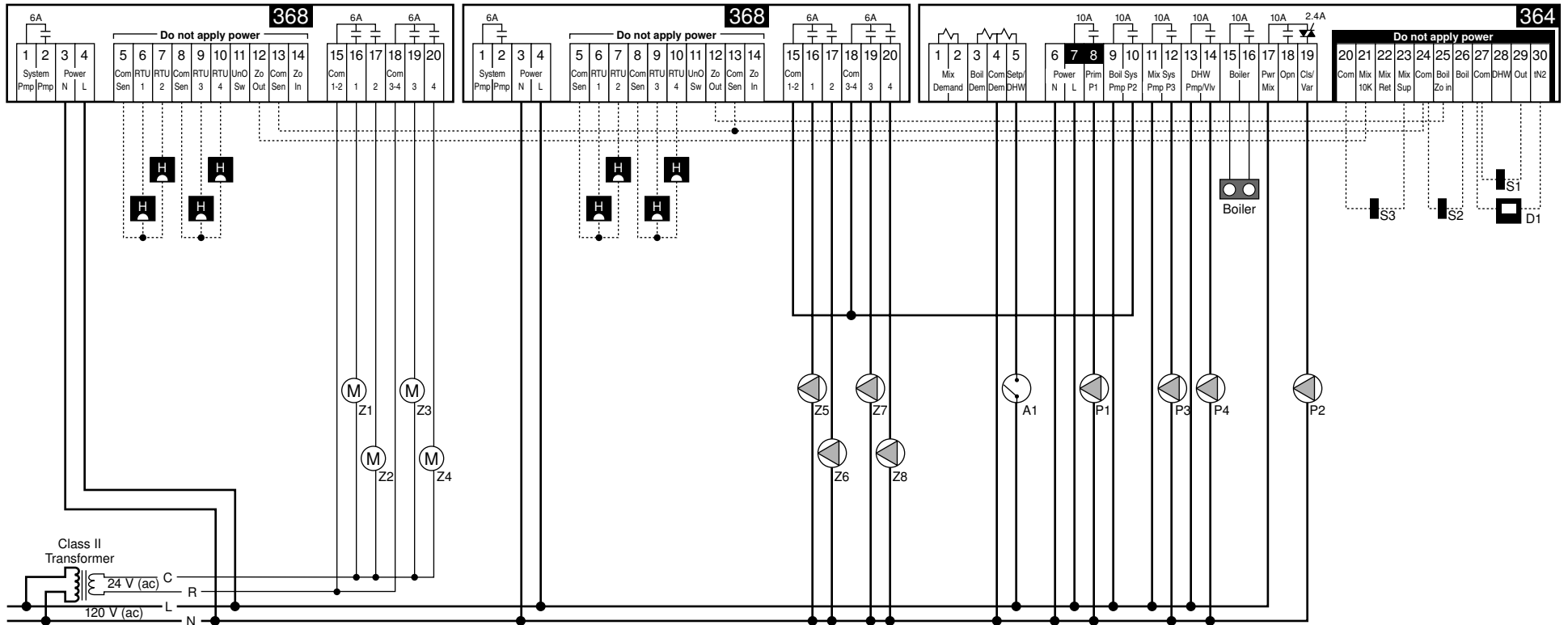

11 of 12

© 2001 tekmar® A 364 - 07/01

Concept Drawing

This is only a concept drawing, not an engineered drawing. It is not intended to describe a complete system, nor any particular system. It is up to the system designer to determine the necessary components for and configuration of the particular system being designed, including additional equipment, isolation relays (for loads greater than the control's specified output ratings), and any safety devices which in the judgement of the designer are appropriate, in order to properly size, configure and design that system and to ensure compliance with building and safety code requirements.

Essential Control Settings

364: DIP Switch = Mixing Reset
 MIXING = VAR
 DHW THRU = PUMP

MIX 10K = ZOIN
 Boil SENS = SUP
 DHW SENS = NONE

Specifications

The following are the recommended specifications for the Universal Reset Control 364.

- The control shall provide two outdoor reset temperatures. The outdoor reset strategy shall be characterized to the heating system and shall have adjustments for the outdoor design temperature, indoor design temperature, design supply temperature and terminal unit.
- The control shall have the option to directly operate a variable speed injection pump or a mixing valve with a floating action actuator motor.
- The control shall have the option to provide heat through the mixing device to either a space heating system or a snow melting system.
- The control shall have an adjustable Minimum Supply water temperature setting to help prevent condensation of flue gases and subsequent corrosion and blockage of the boiler's heat exchanger and chimney.
- During extended periods of inactivity, the pumps and valves that are operated by the control shall be periodically exercised to prevent seizure during long idle periods.
- The control shall provide heat to the space heating system as needed unless the outdoor air temperature is warmer than the control's Warm Weather Shut Down (WWSD) temperature setting.
- The control shall have the option of an automatic differential calculation for the operation of a single boiler in order to prevent short cycling.
- The control shall have the ability to directly control the boiler supply temperature or to send a boiler enable signal to another boiler operating control to allow for a staging control to be connected.
- The control shall have four separate lockable access levels to limit the number of adjustments available to various users.
- The control shall have a test button that activates a pre-programmed test sequence testing all of the control's outputs.
- The control shall show a number of current sensor temperatures depending on the access level that has been selected.
- The control shall continuously monitor its temperature sensors and provide an error message upon a control or sensor failure.
- The control shall have the option of connecting a Remote Display Module to allow for remote monitoring and adjustment of the control.
- The control shall have the ability to operate a domestic hot water (DHW) system that uses either a zone valve or pump to control the flow to the DHW heat exchanger.
- The control shall have the ability to provide DHW priority and to limit the maximum allowed DHW priority period based on the outdoor air temperature.
- The control shall have the option of using either a DHW aquastat or a DHW sensor to control the DHW tank temperature.
- When operating a snow melting system, the control shall have the ability to limit the rate of rise of the snow melting supply temperature in order to prevent thermal shock of the snow melting system.
- The control shall have the ability to limit the amount of cool water being returned to the boiler through the mixing device in order to prevent low boiler operating temperatures and flue gas condensation.
- The control shall use slab outdoor reset when operating a snow melting system to prevent slab freeze up during sudden drops in outdoor temperature.
- The control shall have the option of connecting a Remote Start / Stop Module when operating in the snow melting mode.



tekmar Control Systems Ltd., Canada
tekmar Control Systems, Inc., U.S.A.
Head Office: 4611 - 23rd Street
Vernon, B.C. Canada V1T 4K7
(250) 545-7749 Fax. (250) 545-0650
Web Site: www.tekmarcontrols.com