

tekmar [®] form	Service Bulletin	SB 032 July 26, 2007	v0011
------------------------------------	-------------------------	--------------------------------	--------------

Modulating Boiler Interface: Revision 7

The tekmar 263, 265, 270, 420*, 422*, and 423* allow for the operation of modulating boilers which can fall into one of two categories:

1. Modulating boilers with external mounted power burners and mod motors. These boilers are custom ordered and therefore a compatible power burner can be chosen. Examples of power burners include:

Beckett
Carlin
Gordon Piatt
Power Flame
Riello
Webster
Weishaupt

2. Modulating boilers with built-in controls. The table shown on the next page lists whether a particular make and model of boiler is compatible.

* Note: The 420, 422, and 423 are compatible with 0 – 10 V (dc) boilers only.

** The list is complete as of July 2007.

Boiler Manufacturer	Model	Compatible	0-10 V(dc)	4-20 mA	0-135 Ohm	On/Off Enable	OEM Adapter	Service Bulletin
Aerco	KC	Y	N	Y	N	N	N	
Aerco	Benchmark	Y	N	Y	N	N	N	
Ajax	Atlas	Y	N	Y	N	Y	N	
Allied Engineering	Super Hot AAE	Y	N	N	Y	Y	tekmar 005	
Allied Engineering	Super Hot Saturn	Y	N	N	Y	Y	tekmar 005	
Baxi	Luna	N	N	N	N	N	N	
Biasi	Riva	N	N	N	N	N	N	
Buderus	GB142	Y	Y	N	N	N	EM10 Module	SB 040
Burnham	CHG	Y	Y	N	N	N	AM4 Module	
Burnham	Freedom CM	Y	Y	N	N	N	AM4 Module	
Camus	Dynaflame	Y	N	Y	N	Y	N	
Cleaver-Brooks	Clearfire	Y	Y	N	N	N	AM4 Module	SB 031
Crown Boilers	Bimini BWC	Y	Y	N	N	N	AM4 Module	
Dunkirk	Q90-100	N	N	N	N	N	N	
Dunkirk	Q90-200	N	N	N	N	N	N	
Dunkirk	Q95M-200	Y	Y	N	N	N	HAM (AM4 Module)	
Embassy	Ambassador	N	N	N	N	N	N	
Energy Kinetics	EKPak	N	N	N	N	N	N	
Fulton	Pulse	Y	N	Y	N	N	N	
Gasmaster	GMI series	Y	Y	N	N	Y	N	
Hamilton Engineering	EVO Duo	Y	Y	N	N	Y	N	
Heat Transfer Products	Munchkin	Y	Y	N	N	N	Interface Board	SB 037
Hydrotherm	KN series	Y	N	Y	N	N	N	
Hydrotherm	GX series	N	N	N	N	N	N	
IBC	15-150	Y	Y	Y	N	N	N	
Laars	Endurance	N	N	N	N	N	N	
Laars	Mascot	N	N	N	N	N	N	
Laars	Mighty Therm HH	Y	N	Y	N	Y	N	
Laars	Rheos	Y	Y	N	N	Y	N	
Laars	Summit	N	N	N	N	N	N	



Service Bulletin

SB 032

July 26, 2007

v0011

Boiler Manufacturer	Model	Compatible	0-10 V(dc)	4-20 mA	0-135 Ohm	On/Off Enable	OEM Adapter	Service Bulletin
Lochinvar	Knight	Y	Y	N	N	Y	N	SB 038
Lochinvar	Intellifin	N	N	N	N	N	N	
Lochinvar	PowerFin	Y	Y	Y	N	Y	KIT3096	SB 033
NY Thermal	Trinity	N	N	N	N	N	N	
Patterson Kelley	Mach	Y	Y	N	N	N	N	
Patterson Kelley	Modu-Fire	Y	N	Y	N	N	N	
Peerless	Pinnacle	Y	Y	N	N	N	Interface Adapter	SB 037
Quietside	QVW8 / QVM9	N	N	N	N	N	N	
RBI	Futera III	Y	N	Y	N	Y	N	
RBI	8800	Y	N	N	Y	Y	tekmar 005	
RBI	8900	Y	N	N	Y	Y	tekmar 005	
Slant/Fin	Lynx	N	N	N	N	N	N	
Thermal Solutions	Evolution	Y	N	Y	N	Y	N	
Triangle Tube	Prestige Solo	Y	Y	N	N	N	AM4 Module	SB 041
Utica	UB95M-200	Y	N	N	N	N	HAM (AM4 Module)	
Viessmann	Vitodens 200	N	N	N	N	N	N	SB 035
Viessmann	Vitodens 100	N	N	N	N	N	N	
Weil-McLain	Ultra	Y	Y	N	N	N	AM4 Module	SB 031

Regarding the installation of 4 or more Boilers

It is possible to connect multiple modulating boilers to a single modulating output. The value of the Input Impedance of each boiler is required before multiple boilers are connected. The Input Impedance can be thought as the resistance of the boiler modulating circuit. This cannot be measured using an ohmmeter. Due to continual changes within boiler equipment, it is recommended to contact the boiler manufacturer or modulating equipment manufacturer to determine the Input Impedance.

0 – 10 V (dc) Input Signal

When using a 0 – 10 V (dc) signal, multiple boilers can be connected to the modulating output in parallel. As more boilers are added to a single modulating output, it introduces more error to the signal. The error affects the accuracy of the firing rate of the boiler and limits the range of the modulating boiler. For example, the control may output a signal for 100% fire and the boiler will only receive a signal to fire to 98%. The amount of error can be determined using the following formula:

$$\%Error = \left(\frac{1.02 * R}{R + (510 * N)} - 1 \right) * 100\%$$

where R is the Input Impedance of the boiler and N is the number of boilers added in parallel.

For example: The Weil-McLain Ultra AM4 module has an input impedance of 66,000 Ohms (As of June 2004). If 3 Ultra boilers are connected to a single modulating output:

$$\%Error = \left(\frac{1.02 * 66000}{66000 + (510 * 3)} - 1 \right) * 100\% = \left(\frac{67320}{67530} - 1 \right) * 100\% = -0.31\%$$

The amount of acceptable error in the modulating signal will vary from installer to installer. It is suggested that the error should not exceed $\pm 5\%$.

Wiring Diagram

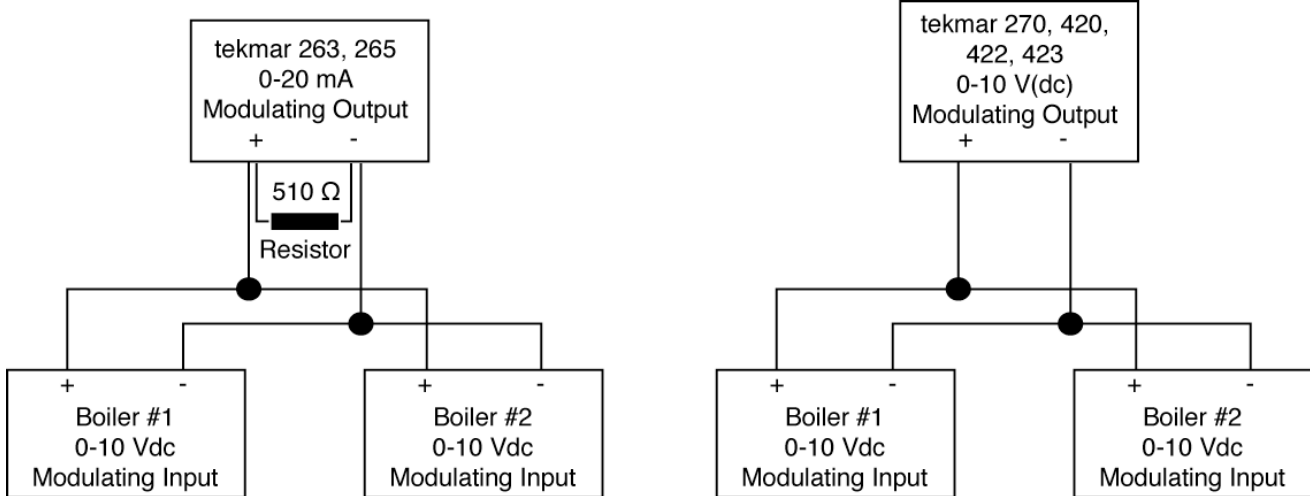

Sincerely yours,

Jay Vath
tekmar Control Systems Ltd